



XP-115  
Multi-Port Power Pack  
Operation and Maintenance Manual



<http://www.TorsionX.com>

# Safety Guide

To use the XP-115 Multi-Port Power Pack safely you must follow correct operation guidelines and inspect the equipment regularly. Read and follow all instructions and put on proper personal protective equipment (PPE) prior to use.

## **UPON RECEIPT OF THIS TOOL, INSPECT THE PACKAGE FOR DAMAGE.**

Carefully inspect all components for damage incurred during shipping. If any shipping damage is found, notify the carrier at once. Shipping damage is NOT covered by warranty. The carrier is responsible for all repair or replacement costs resulting from damage in shipment.

Neither TorsionX, nor its distributors are responsible for damage caused by unsafe and/or faulty operations. If a problem arises during use, shut off the power immediately and consult your TorsionX distributor.

ALL OF OUR PRODUCTS MAY HAVE UPGRADES AND MODIFICATIONS WITHOUT NOTICE.

## Table of Contents

Warnings .....	3
XP-115 Multi-Port Power Pack.....	3
Hydraulic Couplers .....	4
Set Up.....	5
Operation .....	7
Features: .....	7
Warranties .....	8
Trouble Shooting Guide .....	9
Appendix .....	10

# Warnings

## Hydraulic Hose:

- Inspect hose for wear and damage prior to every use.
  - Only use twin line high pressure hydraulic hoses rated for 10,000 PSI with at least a 3:1 safety factor.
  - The maximum operating pressure is 10,000 PSI - Do not exceed 10,000 PSI.
- Do not let the hose kink, twist, curl or bend so tightly that oil flow within the hose is blocked or reduced.
  - The minimum bending radius:  $R > 5$  inch.
  - Too small of a bending radius will kink and destroy the high pressure hydraulic hose.
- Before operating the hydraulic power pack, tighten all hydraulic hose connections with the proper tools.
  - **Do not** overtighten.
  - Connections should be tightened securely and leak-free.
  - Over tightening can cause premature coupler thread failure.
- Shut off the electric motor before breaking any hydraulic connections in the system.
  - Should a hydraulic hose ever rupture, burst, or need to be disconnected, immediately shut off the hydraulic power pack.
  - Never attempt to grasp a leaking pressurized hose with your hands. The force of the escaping hydraulic fluid could cause serious injury.
- **Do not** subject the hose to potential hazards such as:
  - Fire
  - Sharp surfaces
  - Extreme heat or cold
  - Heavy impact
- Hose material and coupler seals must be compatible with the hydraulic fluid.
  - Keep hoses away from contact with corrosive materials such as creosote-impregnated objects and some paints and solvents.
  - Never paint a hydraulic hose.
  - Never paint hydraulic couplers.
  - Hose deterioration due to corrosive materials can result in premature failure and serious personal injury.

## XP-115 Multi-Port Power Pack

- Do not exceed the maximum hydraulic pressure rating of 10,000 PSI.
- Do not tamper with the internal high pressure relief valve.
  - Creating pressure beyond rated capacities can result in serious personal injury.

- Before replenishing the hydraulic oil, retract the system to prevent overfilling the pump reservoir.
  - Overfilling can cause personal injury due to excess reservoir pressure created when the wrenches are retracted.

## Power Supply:

- **Disconnect the hydraulic power pack from the power supply when performing maintenance or repairs.**
  - If the power supply is damaged or the inner wiring is exposed in any way, replace immediately.
  - If the power cord is damaged or wiring is exposed, replace or repair immediately.
  - Check the total amperage draw for the electrical circuit you will be using.
  - Low amperage can cause the power pack to generate excessive heat and may cause the electric circuit breakers to trip.

## Hydraulic Couplers

- Never overtighten the hydraulic coupler.
  - Overtightening can cause premature thread failure.
- Check for gaps in the hydraulic coupler.
  - Gaps can cause a disruption in the flow of hydraulic fluid.
  - Gaps will cause the hydraulic torque wrench to not operate.
- Immediately replace any worn or damaged hydraulic couplers.
- Do not use the hose to move the attached equipment.

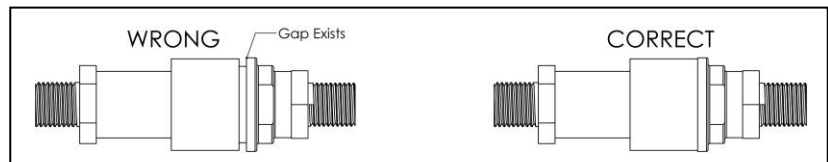

Figure 1



## IMPORTANT

**WHEN ONLY USING ONE HYDRAULIC TORQUE WRENCH, COVER THE EMPTY HYDRAULIC COUPLINGS WITH DUST CAPS.**

**USE A STABLE ELECTRIC SOURCE. IF POWER SUPPLY IS UNSTEADY IT MAY AFFECT THE PERFORMANCE AND MAY DAMAGE THE HYDRAULIC POWER PACK.**

**IF YOU ARE USING AN EXTENSION CORD TO POWER THE HYDRAULIC PUMP, USE A HEAVY GAUGE CORD (12 GAUGE OR BETTER).**

## Operation Warnings:

- **Do not** permit anyone to stand in front of open hydraulic couplers during operation.
- **Never** exceed the maximum operating pressure of 10,000 PSI.
- Before performing any maintenance, shut off power.
- **Do not** operate without oil.
- Keep the power pack clean.
- **Do not** operate in wet conditions.

## Set Up

### Filling the Reservoir:

**Attention:** The power pack has been shipped **without** oil in the reservoir. Only use a high-grade (Grade 46 or better), quality non-foaming hydraulic oil.

1. Clean the area around the filler cap.
  - a. Any dirt or grime in the hydraulic oil can damage the internal workings of the power pack.
2. Remove the filler cap, and insert a clean funnel.
3. Fill with hydraulic oil to 1" from the top of the filler hole.
4. Replace filler cap.
5. Cycle the power pack (with hydraulic torque wrench attached) several times.
6. Retract the hydraulic torque wrench and check the oil level in the power pack reservoir again.
  - a. This will also help eliminate air from the system.

### Hydraulic Connections:

1. Inspect all hydraulic twin line hoses, threads and fittings for signs of wear or damage and replace as needed.
2. Clean all hose ends and hydraulic couplers.
3. Connect the twin line hydraulic hose to the hydraulic torque wrench and the power pack, making sure all hydraulic couplers are snug.
4. Jog the power pack several times.
  - a. The power pack is now ready to be put into regular operation.

## Adjusting the Hydraulic Pressure:

**NOTE:** For easy adjustment of the pressure regulating valve always adjust the pressure by increasing to the desired pressure setting.

1. Loosen the locknut on the pressure regulating valve, and back the adjusting knob out a few turns.
  - a. Do so by turning the adjusting knob in a counterclockwise direction. (Figure 2)
  - b. This will decrease the pressure setting to a pressure lower than the desired pressure.

**IMPORTANT: NEVER EXCEED 10,000 PSI**

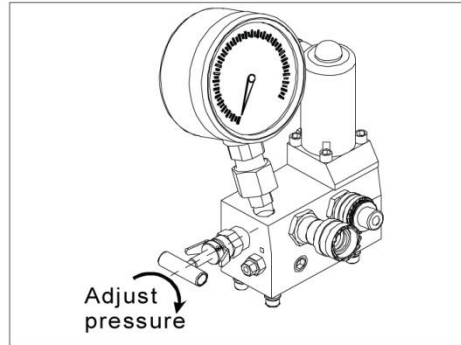

Figure 2

**ATTENTION: THE POWER PACK MUST BE COMPLETELY CONNECTED AND THE HYDRAULIC TORQUE WRENCH MUST NOT BE ON THE APPLICATION WHEN ADJUSTING THE PRESSURE.**

2. Connect the electric power supply and flip the on/off switch to "On"
  - a. This switch is located on the back of the electrical control box.
3. Press the rocker switch on the remote control handle to the center position to turn the power pack on.
  - a. The power pack will deliver hydraulic oil to the low pressure port (Port B).
4. Press the rocker switch on the top position to "Advance".
  - a. The power pack will deliver hydraulic oil to the high pressure port (Port A).
5. While holding remote rocker in the "Advance" position, slowly turn the adjusting knob in a clockwise direction.
  - a. This will gradually increase the pressure setting.
6. When the desired pressure is reached, lock the adjusting knob in position by tightening the locknut.



**IMPORTANT: NEVER EXCEED 10,000 PSI**

# Operation

1. Press the remote rocker switch on the top to advance the hydraulic torque wrench.
  2. When you hear an audible “Click” from the hydraulic torque wrench, release the remote rocker.
    - a. The hydraulic torque wrench will automatically retract.
  3. When the hydraulic torque wrench is fully retracted, repeat the process until the desired pressure/torque rating is reached.
- To disconnect tools and hoses from system, you must release system pressure.
    - a. To release pressure from system, press the rubber button on top of the solenoid. (Figure 3)



Figure 3

**Attention:** When using a hydraulic power pack for the first time, activate the hydraulic torque wrench prior to putting tool on an application; this will help remove any air from the system.

## Features:

- XP-115 Multi-Port Power Pack is a three-stage power pack. The pressure relief valve is assembled in the high pressure port.
- Flow rates for the power pack by stage are:
  - 50in /min in high pressure stage
  - 110in /min in mid pressure stage
  - 500in /min in low pressure stage
- Maximum operating pressure: 10,000 PSI
- The XP-115 Multi-Port Power Pack can simultaneously run two torque wrenches at the same time.
- Electric power options:
  - 115V 60HZ, 1.2 Hp Motor
  - 220V 50HZ, 1.6 Hp Motor
  - 220V 60HZ, 1.6 Hp Motor
- Acceptable working temperature: -20 F to 120 F
- Overall dimensions: 11.8” x 14.8” x 17.9”
- Weight (no oil): 60lbs
- Hydraulic oil: ISO VG 46#

## Warranties

1. TorsionX guarantees the XP-115 Multi-Port Power Pack quality for 12 months from the date of purchase.
2. If any quality issue due to the defects of the materials or workmanship is found within the guarantee period, TorsionX will repair or replace the defective products at TorsionX's discretion.
3. If the equipment is found to be damaged due to negligence, operating the power pack incorrectly, tampering with, or attempting to repair the power pack in part or whole, the warranty is invalidated.



# Trouble Shooting Guide

Malfunction	Reason for malfunction	Solution
The power pack does not start.	Un-suitable power source.	Confirm the power supply meets the pump's specifications.
	The power is not connected.	Check the power connection.
The system has no hydraulic pressure.	The hydraulic couplers are not connected properly.	Tighten or re-install.
	No oil in the tank.	Fill oil.
	Not enough oil in tank.	Fill oil.
	Faulty pressure gauge.	Replace gauge.
The system still has no hydraulic pressure after checking the above.	The hydraulic couplers may have a vacuum lock.	Check hydraulic couplers to hydraulic torque wrench. Inspect couplers to ensure they are completely coupled. Occasionally couplers have to be replaced because the check ball does not stay open due to wear.
Hydraulic couplers are leaking.	The o-ring, is worn or missing in the female hydraulic couplers.	Replace the hydraulic couplers.
The desired hydraulic pressure can not be reached.	The pressure setting for high-pressure relief valve is adjusted too low.	Replace high pressure relief valve.
	Oil is mixed with water.	Replace the oil.
	Pressure relief valve broken.	Replace valve.
	Air may be in system.	Repeat operating the system with no load several times to eliminate air.
	High-pressure relief valve may be loose.	Tighten valve.
	The o-ring for high-pressure relief valve may be worn or missing.	Replace o-rings.
There is a loud noise when the power pack is operated.	The bearing(s) may be worn or broken.	Replace bearing(s).
	Air may be in system.	Repeat operating the system with no load several times to eliminate air.
High-pressure flow is reduced.	Piston or spring may be broken.	Replace piston assembly.
	Hydraulic couplers may be loose.	Tighten hydraulic couplers.
	Oil level may be low.	Fill with oil.
	Oil may be too cold.	Change hydraulic oil to a lighter grade.
	Dirt in pump or filter is clogged.	Replace filter and clean tank.

# Appendix

## DIMENSIONAL DRAWING AND DESCRIPTION OF PARTS

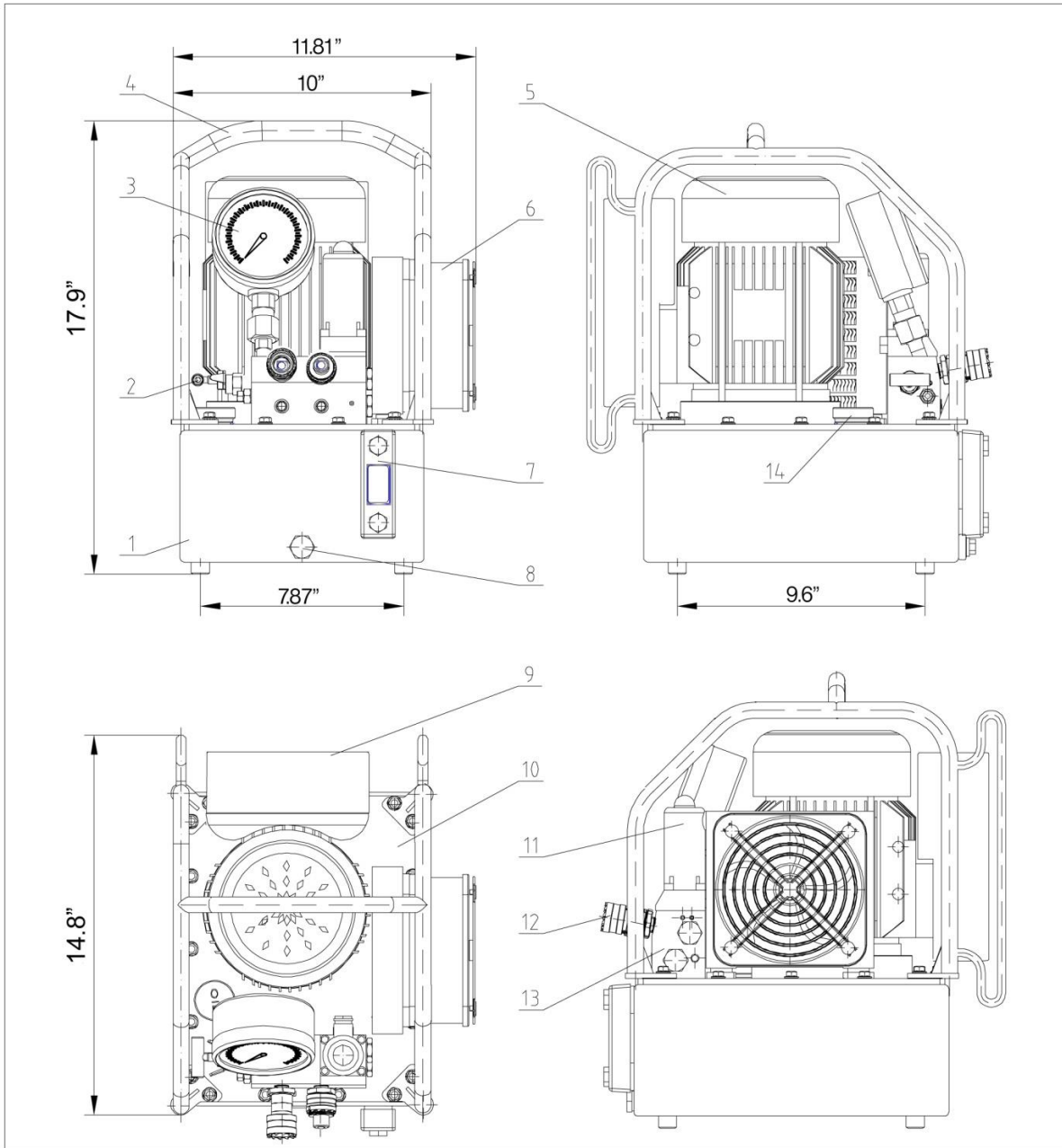

ITEM	DESCRIPTION	ITEM	DESCRIPTION
1	Oil reservoir	8	Oil drain plug
2	External pressure regulator	9	Control box
3	Pressure gauge	10	Cover plate for oil reservoir
4	Roll cage	11	Solenoid valve
5	Electric motor	12	Hydraulic couplers
6	Heat exchanger fan	13	Valve block
7	Oil site gauge oil	14	Oil filler cap

## PART LIST FOR PUMP HEAD

ITEM	DESCRIPTION	QTY
1	Seal Gasket	1
2	Bearing Top	1
3	Bearing Connector	1
4	Pump Body	1
5	Relief Valve Assembly	1
5.1	Relief Valve	1
5.2	Retaining Ring	1
5.3	O-Ring	1
5.4	O-Ring	1
6	Safety Valve Assembly	1
7	Check Valve Assembly	2
7.1	Check Valve	2
7.2	Retaining Ring	2
7.3	O-Ring	2
7.4	O-Ring	2
7.5	Retaining Ring	2
8	Relief Valve Assembly	1
8.1	Relief Valve	1
8.2	Retaining Ring	1
8.3	O-Ring	1
8.4	O-Ring	1
9	Filter Clip	1
10	Screw	1
11	Bearing Middle	1
12	Metal Retaining Ring	1
13	Clip	1
14	Piston	4
15	Piston	2
16	Piston	2
17	Bearing Bottom	1
18	Pin	1
19	Metal Plate	1
20	Screw	1
21	Flange	1
22	Screw	16
23	Screw	1

## PARTS LIST FOR VALVE SYSTEM

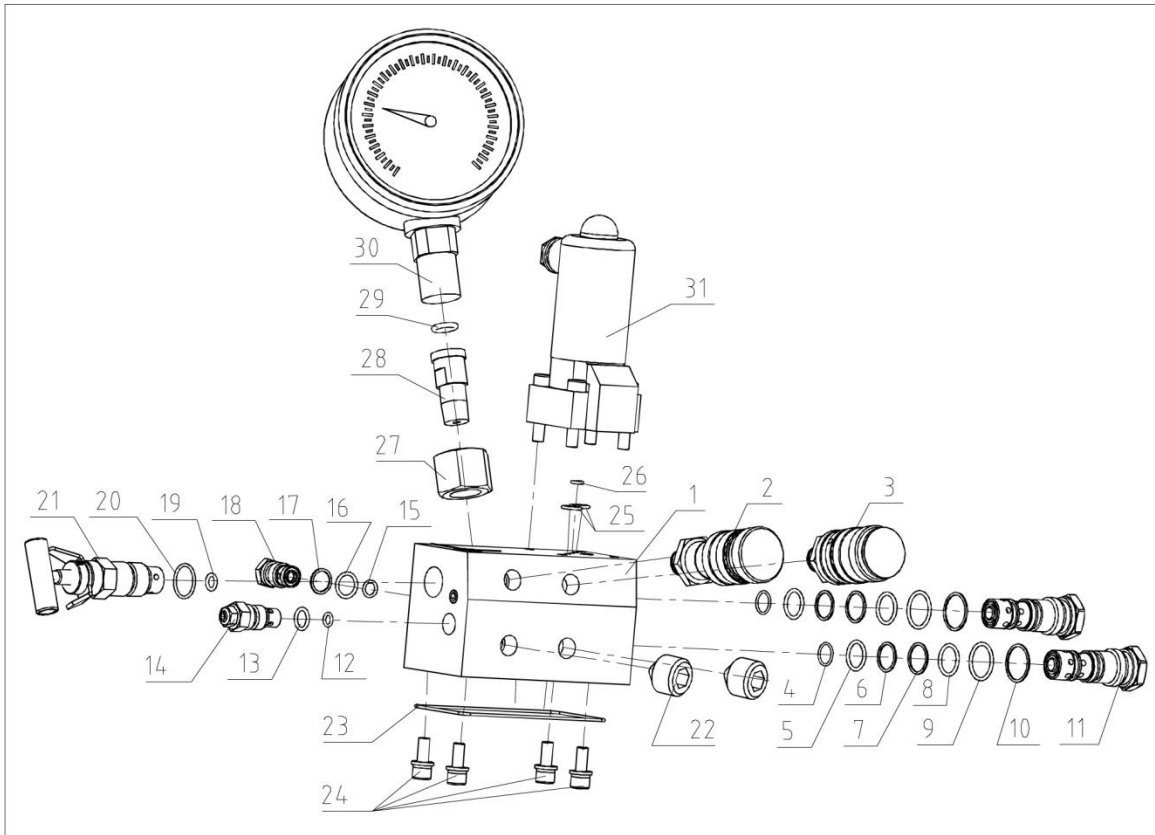

ITEM	DESCRIPTION	QTY	ITEM	DESCRIPTION	QTY
1	Valve block	1	17	Retaining ring	1
2	Male coupler	2	18	Directional control valve	1
3	Female coupler	2	19	O-ring	1
4	O-ring	2	20	O-ring	1
5	O-ring	2	21	Adjusting valve	1
6	Retaining ring	2	22	Casing screw	2
7	Retaining ring	2	23	O-ring	1
8	O-ring	2	24	Screw	4
9	O-ring	2	25	O-ring	2
10	Retaining ring	2	26	O-ring	1
11	Directional valve	2	27	Connector	1
12	O-ring	1	28	Connector	1
13	O-ring	1	29	O-ring	1
14	Adjusting valve return pressure	1	30	Gauge	1
15	O-ring	1	31	Solenoid valve	1
16	O-ring	1			

## ELECTRICAL CIRCUITRY DIAGRAM

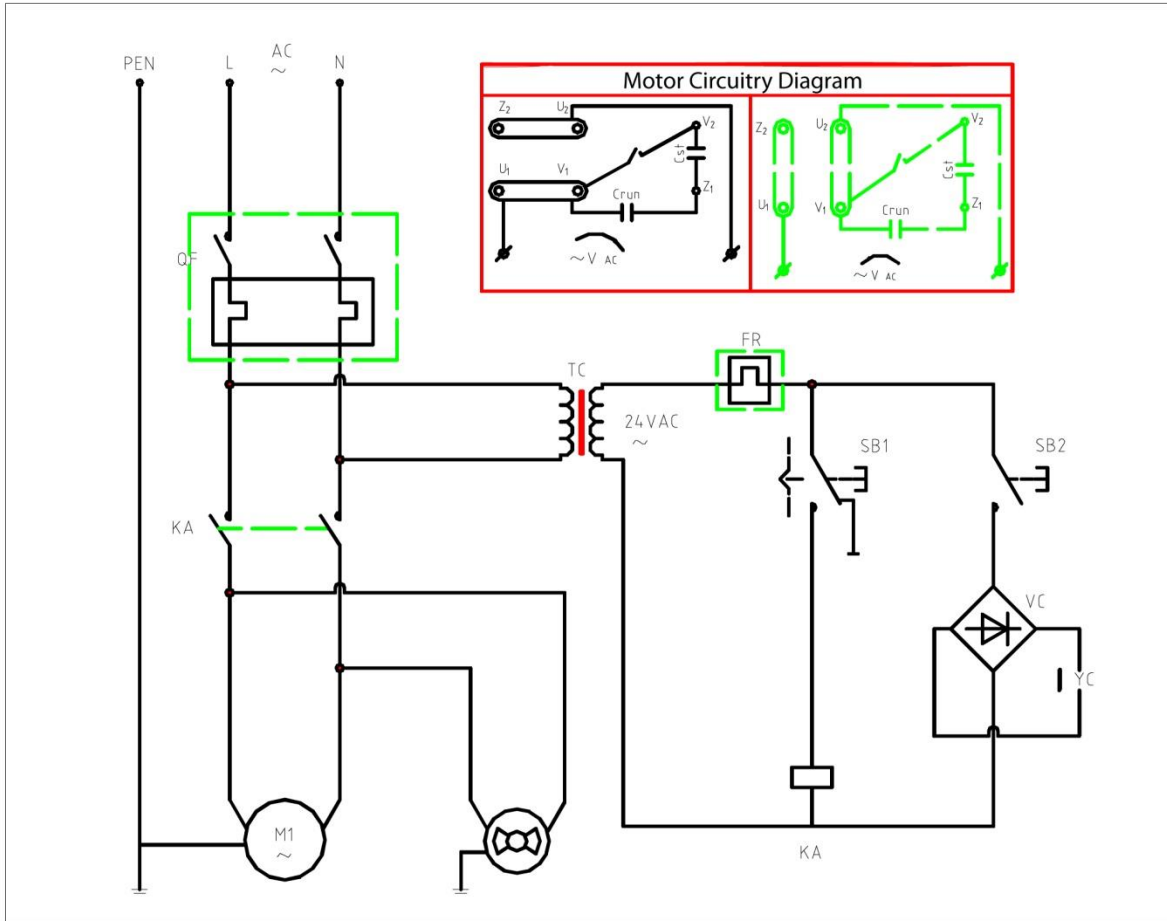

### 115V 60HZ ELECTRICAL CONFIGURATION TABLE:

SYMBOL	NAME	MODEL
CRUN	Working capacitor	70uF 300V.AC
CST	Start capacitor	300uF 150V.AC
YC	Solenoid valve	GZ3-1 24V.DC
VC	Bridge rectifier	KBL2504
Sb1	Remote switch	LAS2GQH-11Z/S/FP
Sb2	Remote switch	GQ16H-10/s
TC	Transformer	TD-30 110V/24V
KA	Relay	JQX-76F-BLU-2A 24V
QF	Start breaker	BS32A
M1	Electric motor	1.25Hp 115V 60HZ
M2	Heat exchanger	38W 110V

**220V 50HZ ELECTRICAL CONFIGURATION TABLE:**

<b>SYMBOL</b>	<b>NAME</b>	<b>MODEL</b>
CRUN	Working capacitor	30uF 450V.AC
CST	Start capacitor	150uF 250V.AC
YC	Solenoid valve	GZ3-1 24V.DC
VC	Rectifier bridge	KBL2504
Sb1	Remote switch	LAS2GQH-11Z/S/FP
Sb2	Remote switch	GQ16H-10/s
TC	Transformer	TD-30 220V/24V
KA	Relay	JQX-76F-BLU 24V
QF	Breaker	BS32A
M1	Electric motor	1.6Hp 220V 50HZ
M2	Heat exchanger	38W 220V

**220V 60HZ ELECTRICAL CONFIGURATION TABLE:**

<b>SYMBOL</b>	<b>NAME</b>	<b>MODEL</b>
CRUN	Working capacitor	30uF 450V.AC
CST	Start capacitor	150uF 250V.AC
YC	Solenoid valve	GZ3-1 24V.DC
VC	Rectifier bridge	KBL2504
Sb1	Remote switch	LAS2GQH-11Z/S/FP
Sb2	Remote switch	GQ16H-10/s
TC	Transformer	TD-30 220V/24V
KA	Relay	JQX-76F-BLU 24V
QF	Start breaker	BS32A
M1	Electric motor	1.6Hp 220V 60HZ
M2	Heat exchanger	38W 220V

## ELECTRICAL SCHEMATIC

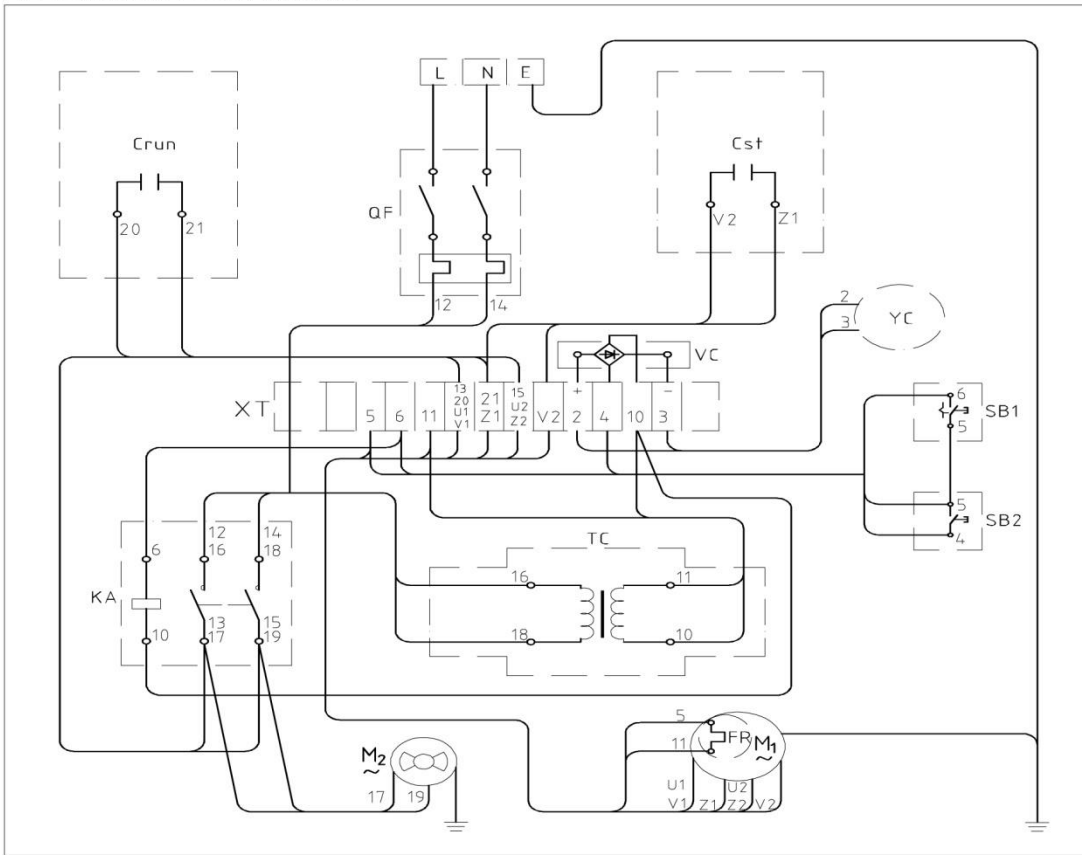

## HYDRAULIC SCHEMATIC

